

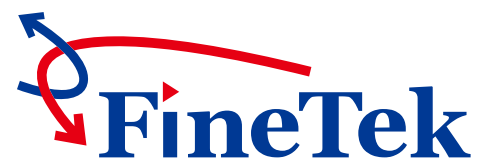

# Sanitary Intelligent Level Switch



[www.fine-tek.com](http://www.fine-tek.com)



# PRODUCT INTRODUCTION

## PRINCIPLE

Working principle of this sensor is based on the frequency sweep technology. The sensor tip will send out electric field signal, and different resonance frequency is created according to different medium. Thus a switching signal will be triggered if the sensor is covered with material.

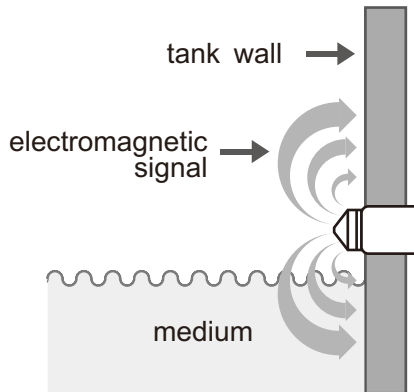

## FEATURE

- Easy installation by standard connection with IP67/IP68/IP695 as protection grade.
- Compact design, easy carry; can be installed in narrow space or stringent operation condition.
- The surface roughness (Ra) can be customized and applicable for Chemical & pharmaceutical and food processing industries.
- With magnetic test function to examine wiring and operation condition in real time.
- Durable stainless housing.
- Real time site-control by LED indicators.
- Overcurrent protection detects over current and shut down the output immediately.
- Workable in CIP and SIP cleaning environment.
- Unaffected by foam and viscous medium.
- Applicable to measure the single-point level of liquid, viscous medium and powder medium in the container and pipe; also providing pump dry run protection.
- It provides 2 output signals and the sensitivity can be set independently; which helps detect 2 kinds of medium.  
(For instance: Oil and water.)

## INSTALLATION EXAMPLES

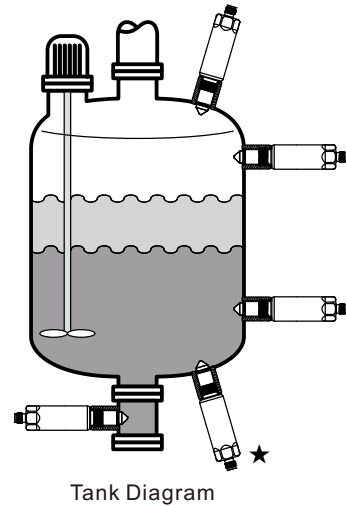

Tank Diagram

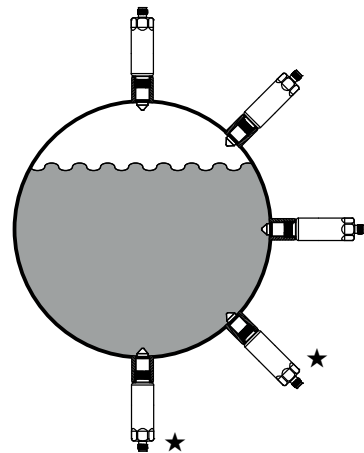

Pipeline Diagram

Top diagram shows the sensors be installed on the container, for instance: monitoring the level or protection pump dry run device.

Below diagram shows the sensors be installed in the pipeline for monitoring the level.

Note: If the medium with strong viscosity, the installation position shows ★ only applicable to certain condition, it may generate failure output signal due the residue be monitored as liquid.

## APPLICATION

With high/low level of material in the process tank or pipeline, alarm of empty material or switch output is particularly suitable for application in the following industries:

- Food manufacturing
- Beverage manufacturing
- Pharmaceutical manufacturing.

# APPLICABLE MEDIUM FORM

Following form, please kindly choose the medium and corresponded default setting. Always ensure the correct setting and corresponded medium.

Attention!! It may cause failure result or unstable operation condition if the application NOT follow the operation range. ● means you can measure the medium based on FineTek default setting.

	Item	Water Based	Low Water Content	Oil Based/ Powder
1	Tap water	●		
2	Seawater	●		
3	Pure water	●		
4	Beer	●		
5	Wine	●		
6	Liquor(40%)		●	
7	Juice (Stock)	●		
8	Juice (Distillate)	●		
9	Milk	●		
10	Yoghurt Drink	●		
11	Vinegar	●		
12	Condensed Milk 7.5%	●		
13	Chocolate(40°C)		●	
14	Syrup		●	
15	Honey		●	
16	Fructose	●		
17	Albumen	●		
18	Yolk		●	
19	Egg(Liquid)	●		
20	Jam(Almond)	●		
21	Jam(Strawberry)	●		
22	Barbecue Sauce	●		
23	Soy Sauce	●		
24	Flour			●
25	Starch			●
26	Cocoa Powder			●
27	Coffee Powder			●
28	Hazelnut Powder(40°C)			●
29	Pepper(Ground)			●
30	Mashed Potatoes			●
31	Creamer(Powder)			●
32	Salt			●
33	Caster Sugar			●
34	Crystal Sugar(Ground)			●
35	Mayonnaise			●
36	Butter		●	
37	Olive Oil			●
38	Palm Oil			●
39	Canola Oil			●
40	Sunflower Oil			●
41	Linseed oil			●
42	Glycerin	●		
43	Mineral Oil(15W40)			●
44	Acetone		●	
45	Methanol	●		
46	Ethanol	●		

# STANDARD SPECIFICATIONS

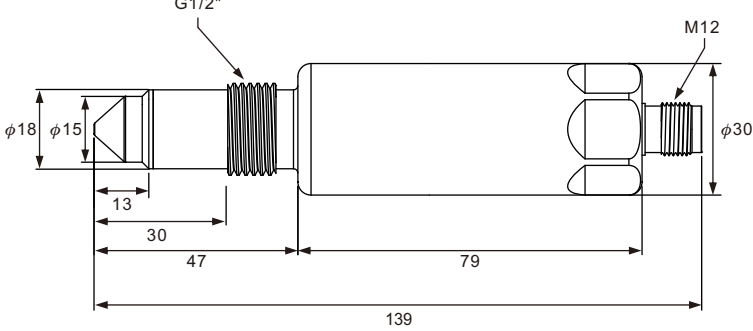
<p>Dimensions (Unit:mm)</p>	
<p>Ambient environment</p>	<p>Water-based media, oil-based media, powder media, dual-level media (such as oil+water), fluid with separation layer (such as bubbles)</p>
<p>Ambient temperature</p>	<p>-40~85°C(-40~185°F)</p>
<p>Process temperature</p>	<p>Max: 100°C (Continuous) while ambient temp.: -40~85°C(-40~185°F) Max: 150°C (Less than 1HR) while ambient temp.: -40~60°C(-40~140°F)</p>
<p>Rated voltage</p>	<p>18VDC~30VDC</p>
<p>Power consumption</p>	<p>Max. 50mA</p>
<p>Over voltage protection</p>	<p>overvoltage category II</p>
<p>Reversal protection</p>	<p>Yes</p>
<p>Switch output (optional)</p>	<p>2 switches: 1<sup>st</sup> NO mode and 2<sup>nd</sup> NC mode.</p>
<p>Output mode</p>	<p>PNP/NPN (optional)</p>
<p>Switch delay function</p>	<p>&lt;1 second(maximum 60 seconds)</p>
<p>Output load current</p>	<p>Max. 100 mA</p>
<p>Voltage drop</p>	<p>Max. 2.5V</p>
<p>Short-circuit protection</p>	<p>Yes, short-time pulse</p>
<p>Overload protection</p>	<p>Yes</p>
<p>Electric connection</p>	<p>M12 4PIN connector</p>
<p>Wetted material (optional)</p>	<p>SUS316、SUS316L</p>
<p>Process pressure</p>	<p>-1~40 bar</p>
<p>Contact specification</p>	<p>G1/2</p>
<p>Probe material/surface Roughness</p>	<p>PEEK/Ra&lt;0.8</p>
<p>Housing protection (optional)</p>	<p>IP67/IP68/IP69K (Under water 1meter, IP68 can last for 30 days).</p>
<p>LED Indicator</p>	<p>Yellow LED for starting, Green LED for resetting</p>
<p>Digital communication</p>	<p>Comply with IO Link V1.1, In pending</p>
<p>Standard compliance</p>	<p>IEC61000-4-2, IEC61000-4-4, IEC61000-4-11</p>

**Warning:**

- 1.The sensor must utilizes FineTek “connector” or “adaptor” then can entitle warranty and working properly and avoid material leaking issue.
2. To achieve IP68/IP69K protection grade, the electrical connection of this device must fit with the M12 electrical cable connection wire in conformity with specifications.

# FUNCTIONS

Output mode	Failure mode	Material level	Output	Output signal	LED indicator
PNP	MAX		OUT1	$\square \xrightarrow{<100 \mu A} \square$	Green
			OUT2	$\square \xrightarrow{I_L} \square$	Yellow
			OUT1	$\square \xrightarrow{I_L} \square$	Yellow
			OUT2	$\square \xrightarrow{<100 \mu A} \square$	Green
	MIN		OUT1	$\square \xrightarrow{I_L} \square$	Yellow
			OUT2	$\square \xrightarrow{<100 \mu A} \square$	Green
			OUT1	$\square \xrightarrow{<100 \mu A} \square$	Green
			OUT2	$\square \xrightarrow{I_L} \square$	Yellow
NPN	MAX		OUT1	$\square \xrightarrow{<100 \mu A} \square$	Green
			OUT2	$\square \xrightarrow{I_L} \square$	Yellow
			OUT1	$\square \xrightarrow{I_L} \square$	Yellow
			OUT2	$\square \xrightarrow{<100 \mu A} \square$	Green
	MIN		OUT1	$\square \xrightarrow{I_L} \square$	Yellow
			OUT2	$\square \xrightarrow{<100 \mu A} \square$	Green
			OUT1	$\square \xrightarrow{<100 \mu A} \square$	Green
			OUT2	$\square \xrightarrow{I_L} \square$	Yellow

- Correspondence output table: OUT 1 sets as NO; OUT 2 sets as NC.
- IL indicates load enabled.

## Wiring Diagram

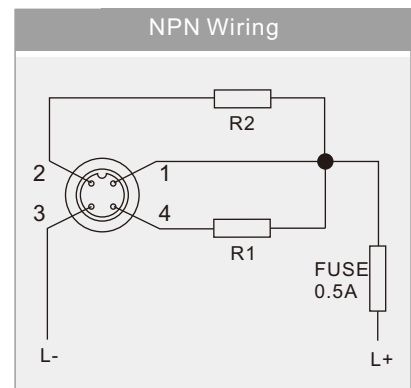
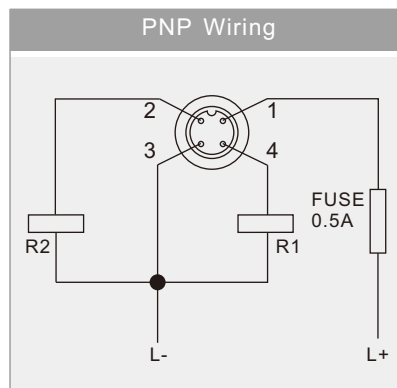
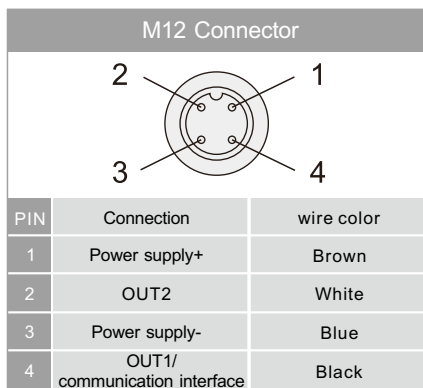

- R1 and R2 indicate the load of OUT1 and OUT2.
- To protect the sensor from abnormal condition, we strongly recommend to adopt FUSE 0.5A on the power supply circuit.
- This wire color only represents the property. The actual wire color depends on the connector purchased.

Note: The accuracy and efficiency can not be guaranteed if using NON-FineTek connector.

# ORDERING INFO

**SIS10**        **B** **R**  **X** **X**

Probe type

0: Standard type

Power supply and output module

0: 18~30Vdc; 2 PNP

1: 18~30Vdc; 2 NPN

Output function

0: OUT1 = NO, OUT2 = NC (Default setting)

1: OUT1 = NC, OUT2 = NO

2: OUT1 = NO, OUT2 = NO

3: OUT1 = NC, OUT2 = NC

Certification

0: N/A

Medium type

0: Water-based(Dielectric constant  $\epsilon \geq 15$ )

1: Oils, greases, powders (Dielectric constant  $\epsilon \leq 15$ )

2: With low water content or viscous (Dielectric constant  $\epsilon \leq 15$ )

Wetted material

1: SUS316

2: SUS316L

Connection

B: 1/2"

Connection Type

R: PF(G)

Probe material and surface roughness

0: PEEK/Ra<0.8

Probe length

# ACCESSORIES - THREAD CONNECTOR/ADAPTOR (OPTIONAL)

Thread connector (While sensor welded aside tank wall) specification:

Connection specification	Weld opening	Exterior dimension	Technical parameters		
G 1/2"	φ45mm		Material	Product part No.	
			SUS316	SISB-000701	
			SUS316L	SISB-000702	
	Application:			<ul style="list-style-type: none"> <li>Structural resistance to pressure 50Bar</li> <li>Reinforced structure of welding beads φ45</li> </ul>	
	φ45mm		Material	Product part No.	
			SUS316	SISB-000801	
			SUS316L	SISB-000802	
	Application:			<ul style="list-style-type: none"> <li>Structural resistance to pressure 50Bar</li> <li>Reinforced structure of welding beads φ45</li> <li>With drain hole</li> </ul>	
	φ29mm		Material	Product part No.	
			SUS316	SISB-000301	
			SUS316L	SISB-000302	
	Application:			<ul style="list-style-type: none"> <li>Structural resistance to pressure 50Bar</li> <li>For storage tank DN25~DN100</li> </ul>	
φ29mm		Material	Product part No.		
		SUS316	SISB-000401		
		SUS316L	SISB-000402		
Application:			<ul style="list-style-type: none"> <li>Structural resistance to pressure 50Bar</li> <li>For storage tank DN25~DN100</li> <li>With drain hole</li> </ul>		
φ30mm		Material	Product part No.		
		SUS316	SISB-000501		
		SUS316L	SISB-000502		
Application:			<ul style="list-style-type: none"> <li>Structural resistance to pressure 50Bar</li> <li>For storage tank</li> </ul>		
φ30mm		Material	Product part No.		
		SUS316	SISB-000601		
		SUS316L	SISB-000602		
Application:			<ul style="list-style-type: none"> <li>Structural resistance to pressure 50Bar</li> <li>For storage tank</li> <li>With drain hole</li> </ul>		

Thread adaptor (for small to large diameter installation) specifications

Female thread specification	Male thread specification	Exterior dimension	Technical parameters	
None	G 1/2"		Material	Product part No.
			SUS316	SISB-000901
			SUS316L	SISB-000902
			Application: <ul style="list-style-type: none"> <li>The sealing plug is used to close up any hole on the device to prevent leakage.</li> <li>Locking torque 30~50Nm</li> </ul>	
G 1/2"	G 3/4"		Material	Product part No.
			SUS316	SISB-000101
			SUS316L	SISB-000102
	3/4"NPT		Material	Product part No.
			SUS316	SISB-001001
			SUS316L	SISB-001002
Application: <ul style="list-style-type: none"> <li>Small to large diameter connector</li> <li>Thread installation for probe connector G 1/2" in G 3/4"</li> </ul>				
Application: <ul style="list-style-type: none"> <li>Small to large diameter connector</li> <li>Thread installation for probe connector G 1/2" in 3/4"NPT</li> </ul>				

**Instructions for using the thread connector and adaptor**

- For application related to food and environmental hygiene EHEDG or 3A standards, please comply with requirements stipulated in laws and regulations.
- The 3A certification specified here applies only to the sealed sensor equipped with PEEK probe.
- The surface should not be contaminated or damaged.
- Welding must be performed by authorized professionals.
- Do not install the sensor when it is cooling down during or after welding.
- The material of the welding rod must meet connector and tank (pipeline) standards.
- The welding power and degree of penetration must meet the tank (pipeline) wall thickness and requirements stipulated in laws and regulations.
- Welding should not cause any deformation to the thread connector, which may hinder installation.
- The seal of the thread connector should not be damaged by weld spatter or collision.

### Installation of thread connector

1. Drill a hole in the tank/pipeline wall while in installation position based on the external diameter of the “thread connector” with a maximum tolerance of + 0.2mm.
2. Perform dot welding with sufficient strength of 8 points in the junction between the tank/pipeline wall and the “thread connector”, with the same spacing as shown in Figure 1
3. Weld the section between the two points as well as the opposite section. Finish the operation by section based on Figure 2. This is mainly to avoid welding stress and overheating, which may result in deformation of the “thread connector” and affect installation.
4. After welding is completed, there should be enough time for the “thread connector” to cool down before installing the sensor.
5. The screw thread and sealing surface should have no welding traces and damage.
6. If the sealing surface of the “thread connector” is damaged, it can no longer be used. In this case, replace the item and repeat the welding process.

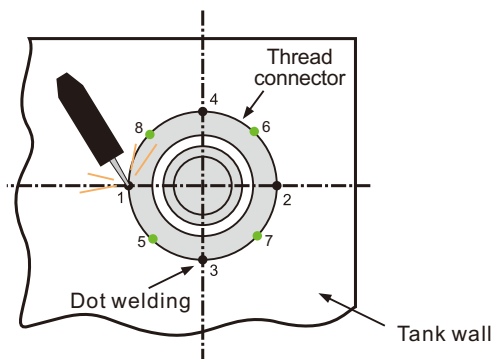

(Figure 1)

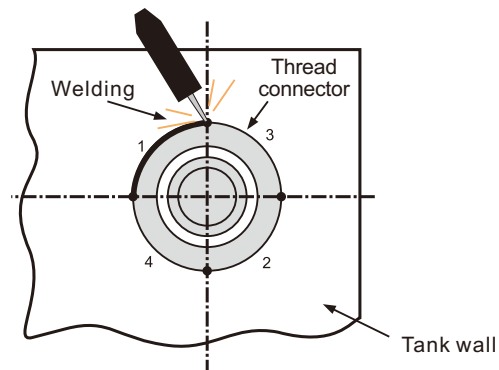

(Figure 2)

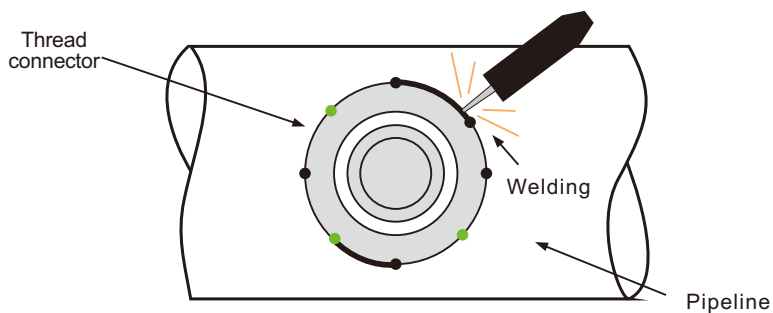

Pipeline welding(Figure 3)

# ORDERING INFO (CONNECTOR/ADAPTOR)



**SISB**

Inner screw thread specifications

00: G 1/2"

External structure and screw thread specifications

- 01 : G 3/4"External screw thread
- 02 : G 1"External screw thread
- 03 : Welding connector  $\phi 29$
- 04 : Welding connector  $\phi 29$ (with drain hole)
- 05 : Welding connector  $\phi 30$
- 06 : Welding connector  $\phi 30$ (with drain hole)
- 07 : Reinforced welding bead connector  $\phi 45$
- 08 : Reinforced welding bead connector  $\phi 45$ (with drain hole)
- 09 : Sealing plug
- 10 : 3/4"NPTEexternal screw thread

Certification

0 : N/A

Material and surface roughness

- 1: SUS316, Ra<0.4
- 2: SUS316L, Ra<0.4

# ACCESSORIES-ELECTRICAL CABLE CONNECTOR (OPTIONAL)

## M12 Electrical Cable Connector

Code: 26-0522-5M

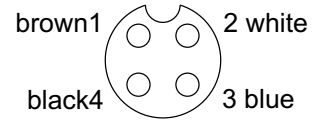
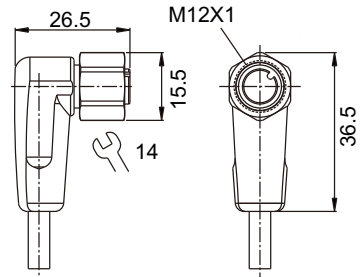

Code: 26-0523-5M

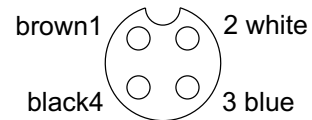
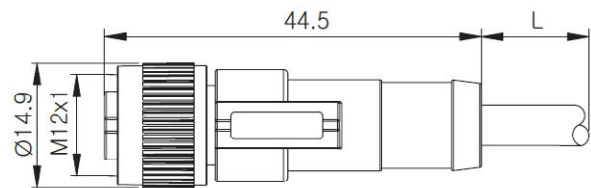

Code: 26-0524-5M

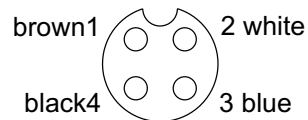
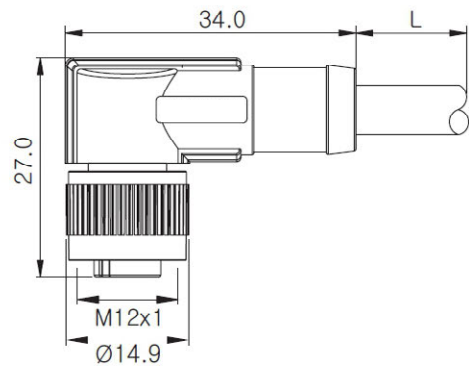

Code: 26-0525-5M

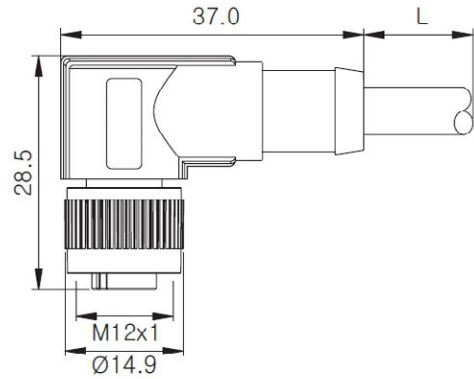
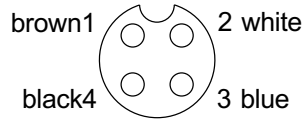
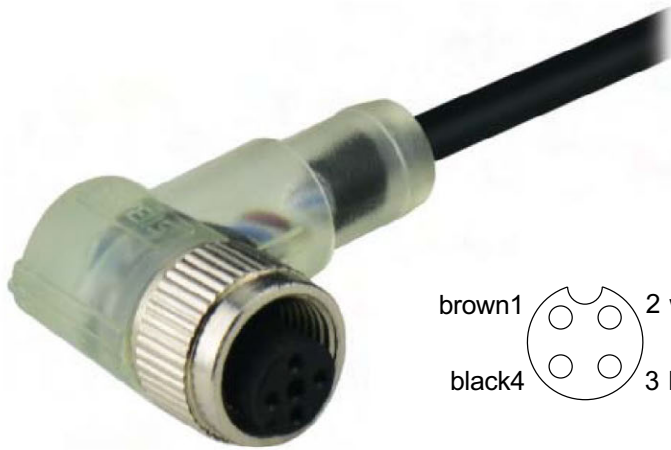

Code: SCA-3371

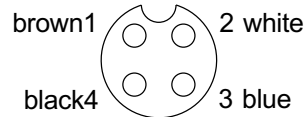
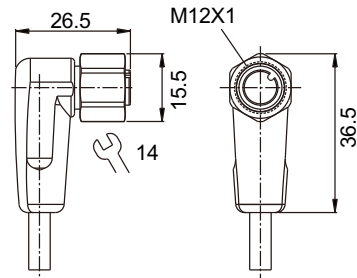

### M12 Connector Specifications

Product part No.	Connector type	Cable length	Voltage rating	Current rating	Working temp.	Protection grade	Coating color	LED indicator
26-0522-5M	Elbow 90°	5m	250Vac/300Vdc	Max.4A	-25°C~100°C	IP67 IP68 IP69K	Orange	NO
26-0523-5M	Straight 180°	5m	250Vac	Max.4A	-25°C~80°C	IP67	Blue	NO
26-0524-5M	Elbow 90°	5m	250Vac	Max.4A	-25°C~80°C	IP67	Blue	NO
26-0525-5M	Elbow 90°	5m	36Vac	Max.4A	-25°C~80°C	IP67	Gray	YES
SCA-3371	Elbow 90°	5m	10~36Vac	Max.4A	-25°C~100°C	IP67 IP68 IP69K	Orange	YES

# ACCESSORIES - PROGRAMMER BOX (OPTIONAL)

## Programmer Box



Product part No	SISB-PA000
Exterior dimension(mm)	87X61X50(L XW XH)
Voltage rating	5Vdc(from USB)
Current consumption	Max.500mA
Input interface	Mini USB
Output interface	M12-5C A-Coded
Ambient temperature	-20°C~45°C(-4°F~113°F)
Protection grade	IP20

The programmer box function is to transmit sensor data to PC for reading and editing. Mainly supports calibration and parameter setting for SIS Sanitary intelligent level switch.

- Reading current sensor parameter setting.
- Changing sensor parameter setting.
- Adjusting sensor sensitivity of current medium in real time.
- Calibrating current measuring value and do necessary adjustment promptly..

Note: The programmer box is only working while sensor data requiring transmit to PC for reading and editing, not a permanent connection automatic device.

## System Diagram

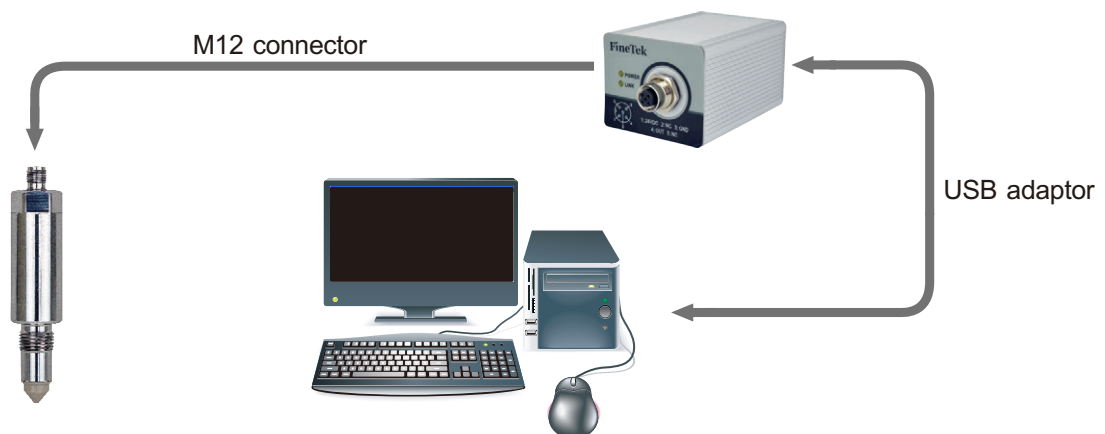

Using M12 connector to link SIS Impedance Spectroscopy Sensor” with programmer box.

Transmitting the sensor data by USB cable from programmer box to PC.

Note: The accuracy and efficiency can not be guaranteed if using NON-FineTek connector.